

- NOTES:
1. ONLY IMPORTANT DIMENSIONS ARE SHOWN ON THE DRAWING.
 2. ALL GEOMETRY SHOULD CORRESPOND WITH THE CAD MODEL. GENERAL TOLERANCES HAVE TO BE APPLIED TO MISSING DIMENSIONS TAKEN FROM CAD MODEL.
 3. PART MUST BE FREE OF BURR AND IMPERFECTIONS THAT MIGHT AFFECT FIT OR FUNCTION.

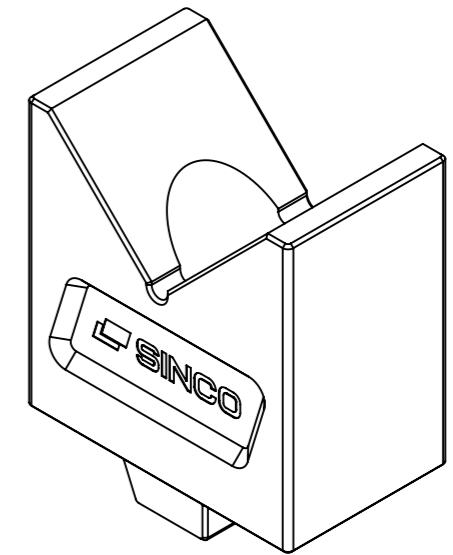
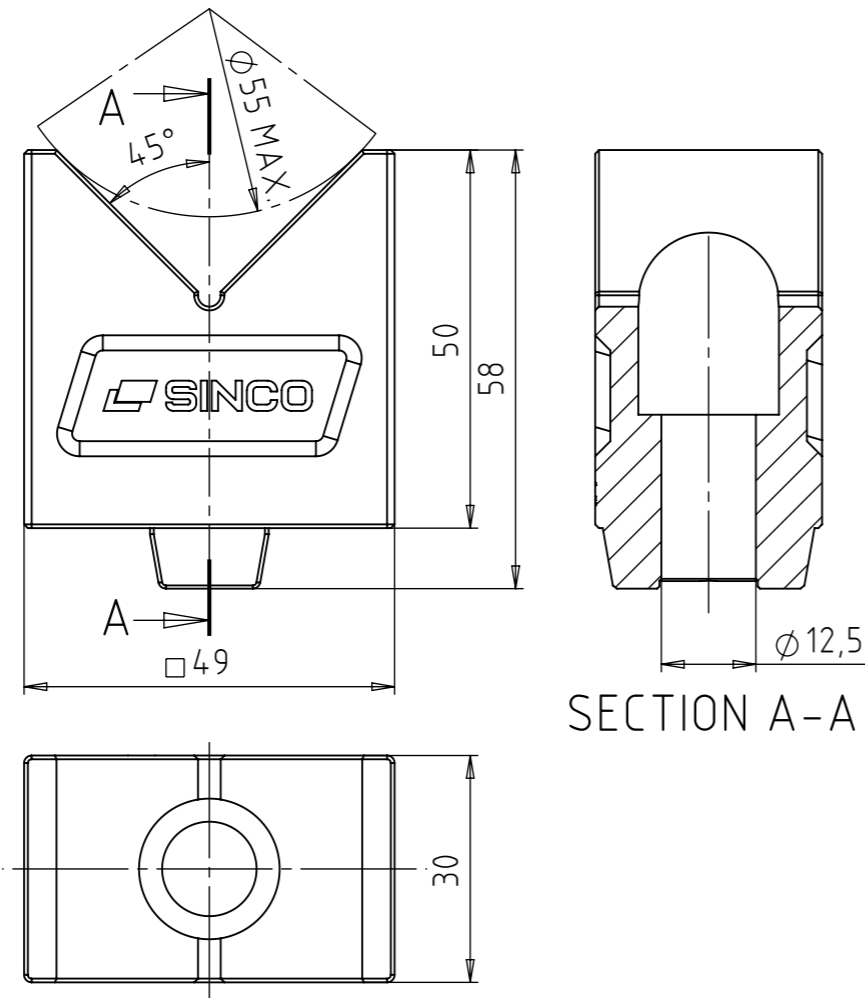

ISOMETRIC VIEW

SECTION A-A

No.	DATE	REVISION RECORD	SIGN.
-	24.02.2025.	NEW	S.S.

ISO TOL.	PROJ. EUROPE	SCALE: 1:1	DO NOT SCALE DRAWING																				
	NAME: Sinko S.	SIGNATURE:	DATE: 24.02.2025.	PART NAME: MZ PRISMATIC SUPPORT V W30 H50 90																			
	DESIGNED BY:			PRODUCT: -																			
	CONTROL BY:			PART NUMBER: 1A3-2550-0																			
	APPROV. BY: Sinko S.		DATE: 24.02.2025.	DRAWING NUMBER: 1A3-2550-0-C																			
	MATERIAL: -	WEIGHT: 0.42 kg		PROJECT NO: -																			
	RAW DIM: -	HEAT TREATMENT: -		POSITION: -	NO. OF PARTS: -																		
	GENERAL TOLERANCES FOR DIMENSIONS ACC. ISO 2768-1: f			PAPER SIZE: A3																			
	INDICATIONS OF FORM AND POSITION ACC. TO ISO 1101			PAGE: 1																			
	SURFACE ROUGHNESS INDICATIONS ACC. TO ISO 1302			PAGES: 1																			
	<table border="1"> <tr> <th>PERMISSIBLE DEVIATIONS FOR LINEAR DIMENSIONS ISO 2768-1: f EXTRACT</th> <th>SIZE RANGE</th> <th>Up to 3</th> <th>> 3</th> <th>> 6</th> <th>> 30</th> <th>> 120</th> <th>> 315</th> <th>> 1000</th> </tr> <tr> <td>LINEAR TOLERANCE</td> <td></td> <td>±0.05</td> <td>±0.10</td> <td>±0.15</td> <td>±0.20</td> <td>±0.30</td> <td>±0.50</td> <td>±1.00</td> </tr> </table>			PERMISSIBLE DEVIATIONS FOR LINEAR DIMENSIONS ISO 2768-1: f EXTRACT	SIZE RANGE	Up to 3	> 3	> 6	> 30	> 120	> 315	> 1000	LINEAR TOLERANCE		±0.05	±0.10	±0.15	±0.20	±0.30	±0.50	±1.00	Slovenska vas 4j, 8261 Jesenice na Dol., Slovenija Tel: +386 (0)7 49 57 371	
PERMISSIBLE DEVIATIONS FOR LINEAR DIMENSIONS ISO 2768-1: f EXTRACT	SIZE RANGE	Up to 3	> 3	> 6	> 30	> 120	> 315	> 1000															
LINEAR TOLERANCE		±0.05	±0.10	±0.15	±0.20	±0.30	±0.50	±1.00															