

ISOMETRIC VIEW

NOTES:

1. ONLY IMPORTANT DIMENSIONS ARE SHOWN ON THE DRAWING.
2. ALL GEOMETRY SHOULD CORRESPOND WITH THE CAD MODEL. GENERAL TOLERANCES HAVE TO BE APPLIED TO MISSING DIMENSIONS TAKEN FROM CAD MODEL.
3. PART MUST BE FREE OF BURR AND IMPERFECTIONS THAT MIGHT AFFECT FIT OR FUNCTION.
4. MATERIAL: CORROSION RESISTANT STEEL

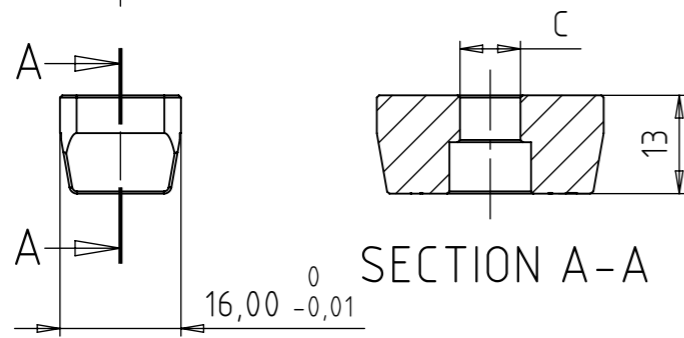
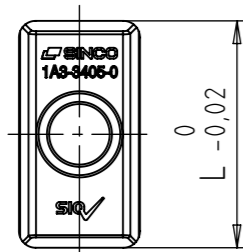

SECTION A-A

INSTALLATION DEFINITION

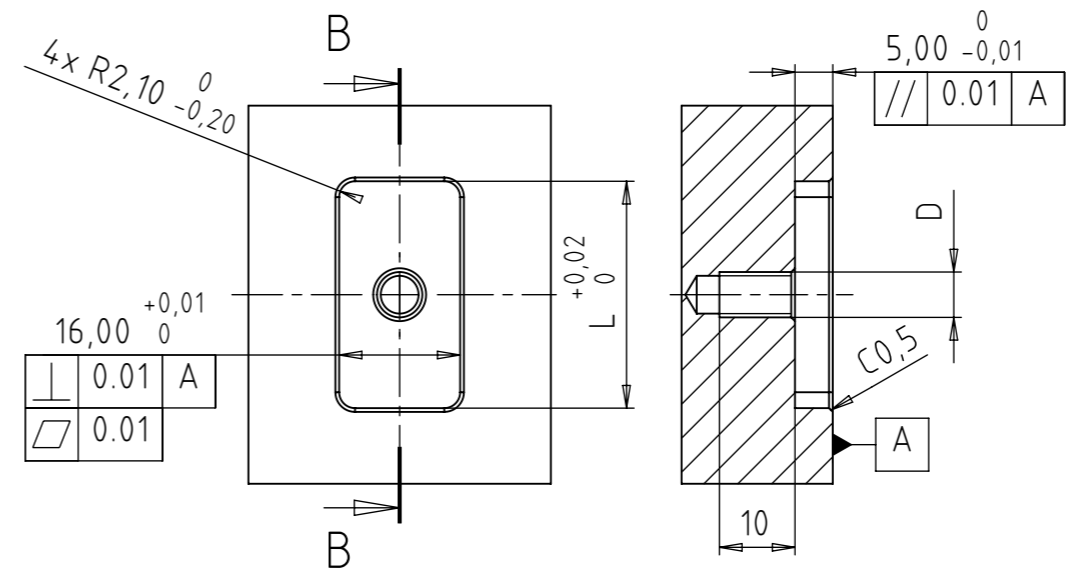

SECTION B-B

	Part name	Part number	L	C	D	Weight (g)
1	MZ Slot Rail W16 L20	1A3-3404-0	20	M6	M5	24
2	MZ Slot Rail W16 L30	1A3-3405-0	30	M8	M6	33
3	MZ Slot Rail W16 L40	1A3-3410-0	40	M8	M6	48
4	MZ Slot Rail W16 L49	1A3-3415-0	49	M8	M6	62

No.	DATE	REVISION RECORD	SIGN.
-	24.02.2025.	NEW	S.S.

ISO TOL.	PROJ. EUROP.	SCALE: 1:1	DO NOT SCALE DRAWING		
	NAME: Sinko S.	SIGNATURE:	DATE: 24.02.2025.	PART NAME: MULTIZERO SLOT RAIL W16 L30	
	DESIGNED BY:			PRODUCT: MULTIZERO ACCESSORIES	
	CONTROL BY:			PART NUMBER: 1A3-3405-0	
	APPROV. BY: Sinko S.		DATE: 24.02.2025.	DRAWING NUMBER: 1A3-3405-0-C	
	MATERIAL: SEE NOTES	WEIGHT: -		PROJECT NO: -	
	RAW DIM: -	HEAT TREATMENT: YES		POSITION: -	NO. OF PARTS: -
	GENERAL TOLERANCES FOR DIMENSIONS ACC. ISO 2768-1: f			PAPER SIZE: A3	
	INDICATIONS OF FORM AND POSITION ACC. TO ISO 1101			PAGE: 1	
	SURFACE ROUGHNESS INDICATIONS ACC. TO ISO 1302			PAGES: 1	
	PERMISSIBLE DEVIATIONS FOR LINEAR DIMENSIONS			SINCO	
	SIZE RANGE	Up to 3	>3 to 6	>6 to 30	>30 to 120
	LINEAR TOLERANCE	±0,05	±0,05	±0,10	±0,15
				Slovenska vas 4j, 8261 Jesenice na Dol., Slovenija	
				Tel: +386 (0)7 49 57 371	