

NOTES:

1. ONLY IMPORTANT DIMENSIONS ARE SHOWN ON THE DRAWING.
2. ALL GEOMETRY SHOULD CORRESPOND WITH THE CAD MODEL. GENERAL TOLERANCES HAVE TO BE APPLIED TO MISSING DIMENSIONS TAKEN FROM CAD MODEL.

A

B

C

D

E

F

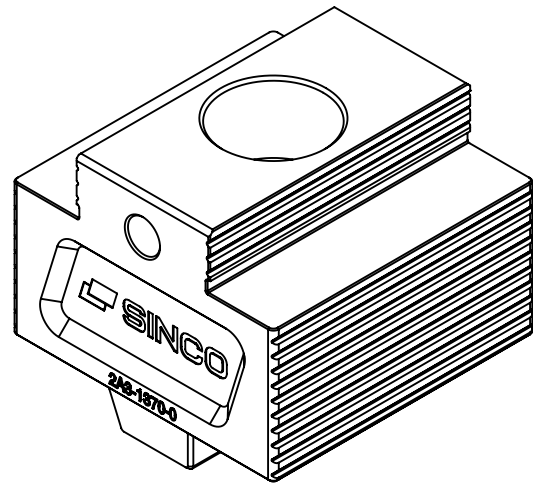

ISOMETRIC VIEW

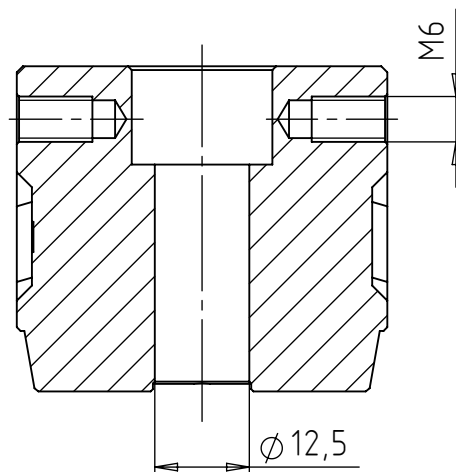
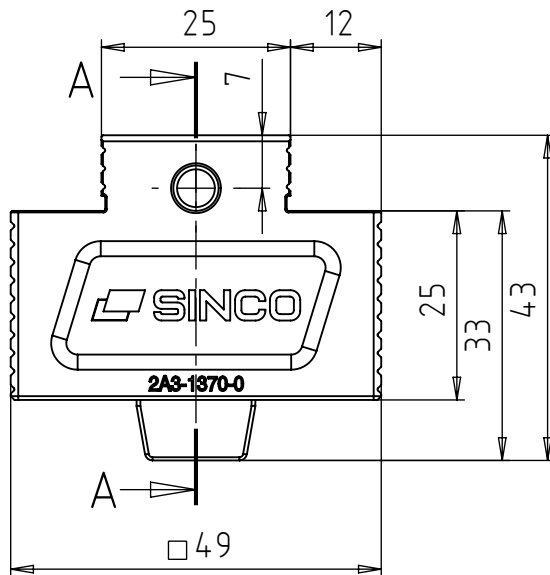

SECTION A-A

-	05.03.2025.	NEW	S.S.
No.	DATE	REVISION RECORD	SIGN.

ISO TOL.	PROJ. EUROP.	SCALE: 1:1	DO NOT SCALE DRAWING	
	NAME: Sinko S.	SIGNATURE:	DATE: 05.03.2025.	PART NAME: MZ SUPPORT W50 L50C H35
	DRAWN BY:	DESIGNED BY:	CONTROL BY:	PRODUCT: MULTIZERO SYSTEM
	APPROV. BY: Sinko S.	DATE: 05.03.2025.		PART NUMBER: 2A3-1370-0
	MATERIAL: CORROSION RESISTANT STEEL	WEIGHT: 0.52 kg		DRAWING NUMBER: 2A3-1370-0-C
	RAW DIM: -	HEAT TREATMENT: 48 Hrc		PROJECT NO: -
	GENERAL TOLERANCES FOR DIMENSIONS ACC. ISO 2768-1: f			POSITION: -
	GEOMETRICAL TOLERANCES ACC. ISO 2768-2: fh			NO. OF PARTS: -
	INDICATIONS OF FORM AND POSITION ACC. TO ISO 1101			PAPER SIZE: A4
	SURFACE ROUGHNESS INDICATIONS ACC. TO ISO 1302			PAGE: 1
	PERMISSIBLE DEVIATIONS FOR LINEAR DIMENSIONS ISO 2768-1 f EXTRACT	SIZE RANGE	Up to 3	PAGES: 1
			>3 to 6	
			>6 to 30	
			>30 to 120	
			>120 to 315	
			>315 to 1000	
			>1000 to 2000	
			>2000 to 40.50	
			>40.50 to 40.50	



Slovenska vas 4 j,
8261 Jesenice na Dol., Slovenija
Tel: +386 (0)7 49 57 371